

Technical
Information

Ethernet

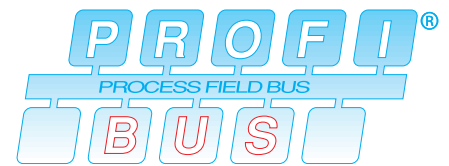

IMPULSES FOR AUTOMATION with Ethernet Interfaces

Gateway EtherGate 692DP

- Gateway between machine and office applications
- Vendor-independent PROFIBUS DP slave
- Low-cost Ethernet networking of old and new PROFIBUS implementations

Gateway EtherGate 692Com

- Gateway between machine and office applications
- Interconnects all RS232 devices and the Ethernet
- Remote programming



System description

As a DP slave, **EtherGate 692DP** just takes a GSD file to connect to every **PROFIBUS** DP master. This simple field bus integration method makes for easy installation at very little effort.

PROFIBUS is the vendor-independent platform which has become as firmly established a site on the automation marketplace as have other field bus systems. It fully covers all of the control and field device levels.

For years, the **Ethernet** has been the most influential networking medium and key factor of office and factory bus applications. Up until now, the networking systems have been designed for clearly distinguished fields of application. Despite the fact that this model of automation levels is increasingly being questioned, there still

need to be low-cost solutions on the market which are capable of inter-connecting the existing structures.

The **PROFIBUS** DP slave ensures vendor independence. The gateway integrates with every **PROFIBUS** DP network by means of a GSD file. The easy interfacing concept applies to both new and, particularly, existing systems. This allows new, innovative networking concepts to be adapted to the available hardware at a minimum of technical and financial effort. Even though the **Ethernet** may gain acceptance in further fields of automation, field bus systems such as **PROFIBUS** will continue to exist. What users demand are technically feasible and economically attractive connectivity solutions.

In its top hat rail housing, **EtherGate 692Com** takes up very little space to provide everything a direct gateway between a serial interface and the computer network requires. All protocols such as the KUBES protocol are supported.

Make use of **EtherGate 692Com** units to substitute for the normal RS232 port. Then run the dedicated PC software to redirect the port. These gateways turn Kuhnke controllers into web servers which are available via the intranet or Internet. The serial and network configuration settings are controlled via Telnet and RARP or ARP.

Networking example

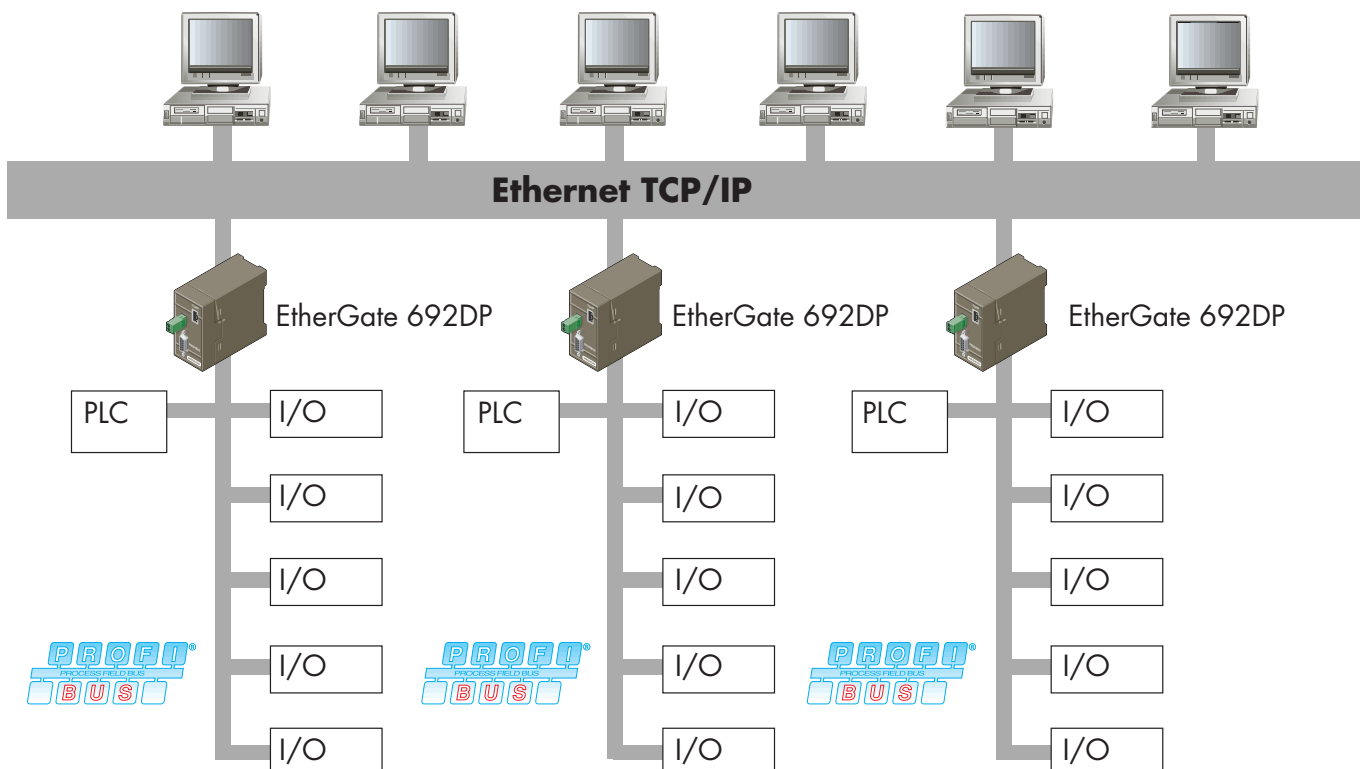

PCs have basically become a standard occurrence in the automation industry. The world of automation increasingly relies on office world methods which imply that the exchangeability of software modules attracts more and more focus. Open interfaces provide the key benefit. Operators who previously wished to visualise their machines had to choose a visualisation software and a PLC that shared the same driver.

OLE for Process Control, or OPC for short, and Microsoft products provide a broad base for the development of driver software for very different visualisation systems. The basic notion of OPC is to make for a vendor-independent, standardised interface between the OPC server and the OPC client which is exactly what the open interface designed by the OPC Foundation is there for. The OPC client requests the OPC server to send the relevant process data which it then outputs to a SCADA application, for example.

The OPC Server is an easy means of addressing all of Kuhnke's automation systems. The OPC Server Kit contains a configuration tool to tell the OPC server the elements of the current hardware configuration. So-called items (variables) enable access routines that the OPC client runs to download current PLC data. OPC Server variants are available for the following types of connection:

- serial port
- PC bus via **PC Control 645**
- Ethernet via **EtherGate 692DP**

Ethernet

EtherGate DP supports the Internet Protocol (IP) with the UDP and TCP protocols added. Selection is made via the header module, which the PROFIBUS master sends to **EtherGate** with every data transfer process.

UDP

This mode provides the compact transfer of serial data across the network, i.e. instead of interrupting the flow of serial data at arbitrary points, all packets are sent through the network as integral packets in their original context. UDP is a non-acknowledging data exchange. It is the user's responsibility to ensure data security.

TCP

TCP is an acknowledging data exchange. The TCP server adds a checksum to the user data it sends. The receiving station looks at the checksum to see if all data of the TCP packet have been received correctly and reports the result back to the server. This ensures that any loss of data will be noticed and that the data packet can be sent again.

TCP Server Mode

Every network station can connect to **EtherGate DP**. If the port currently handles a client process it will reject all other connection requests until the active connection has been closed.

Once a connection has been established the two processes can exchange data bidirectionally.

TCP Client Mode

This mode enables **EtherGate DP** to establish and terminate its own client connection to the specified TCP server. Cyclic PROFIBUS data exchange will prefix a header module to the user data and, in it, will transfer the IP address and TCP server port information.

By means of a "Com routing mechanism", **EtherGate 692Com** turns into a virtual V.24-PC port.

Front and side view

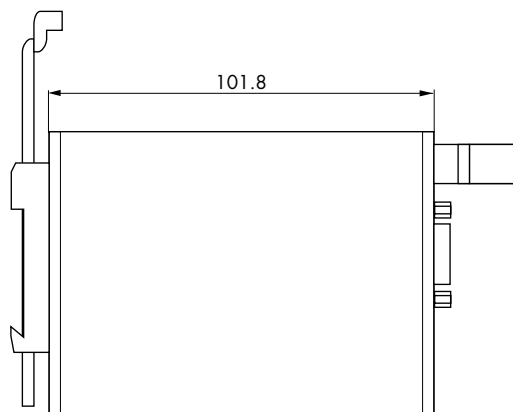
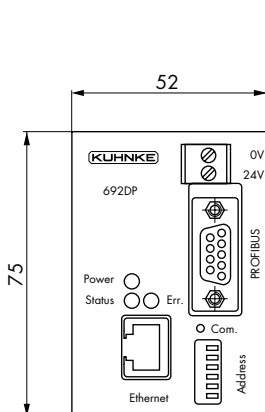

EtherGate 692DP

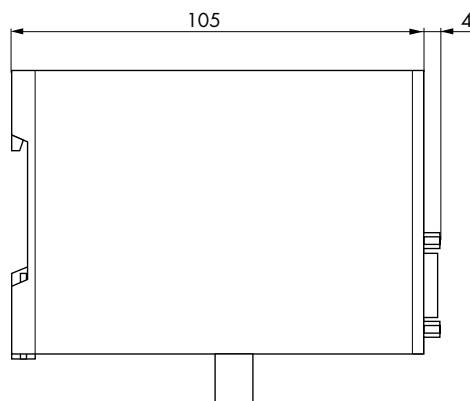
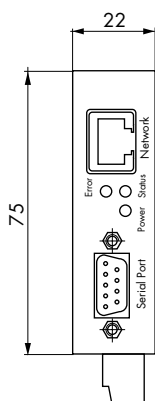

EtherGate 692Com

Technical data

	EtherGate 692DP	EtherGate 692Com
Serial port	PROFIBUS DP	1 x RS232 interface 9-pin Sub-D plug, same pin assignment as PC-Com
Baud rate	max. 12 Mbit/s	300 to 57600 bits/s
Data format	–	7, 8 data bit; 1, 2 stop bit No, Even, Odd Parity
Flow control	–	Yes
Network	10 BaseT	
Housing	Small plastic housing	
Dimensions (mm)	52 x 75 x 101.8	105 x 75 x 22
Weight	approx. 300 g	approx. 200 g
Supply voltage	24 V DC	12 – 24 V AC/DC
Supply connector	Screw-type locking	
Power consumption	200 mA	typ. 65 mA, max. 90 mA @24 V DC
Ambient temperature (operation)	0 – 50 °C	0 – 60 °C
Ambient temperature (storage)	-25 – 70 °C	
Relative humidity	5 – 95 %	
GSD file	KUHN6920.GSD	–
Protection	IP 20	

Order data

Part number	Description
692.012.00	EtherGate 692DP
692.010.00	EtherGate 692Com
645.510.00	OPC Server
E 611 GB	Instruction Manual EtherGate 692DP
E 617 GB	Instruction Manual EtherGate 692Com



KUHNKE.
IMPULSES FOR
AUTOMATION.

Kuhnke GmbH
Lütjenburger Straße 101
D-23714 Malente, Germany

Phone +49 (0) 45 23 / 4 02 -0
Fax +49 (0) 45 23 / 40 22 47
Internet www.kuhnke.com
E-mail sales@kuhnke.de

This data sheet is primarily intended for use by design, project, and development engineers. It does not contain any availability information. Data is only given to describe the product and must not be regarded as guaranteed properties in the legal sense. Any claims for damages – on whatever legal grounds – are excluded except for instances of deliberate intent or gross negligence on our part. We reserve the rights for errors, omissions and modifications.